



Impact of Energy Factors on Default Risk in Commercial Mortgages



Nancy Wallace

Paulo Issler

University of California, Berkeley

Paul Mathew

Kaiyu Sun

Lawrence Berkeley National Laboratory



Updated 2 February 2018

Disclaimer

This document was prepared as an account of work sponsored by the United States Government. While this document is believed to contain correct information, neither the United States Government nor any agency thereof, nor The Regents of the University of California, nor any of their employees, makes any warranty, express or implied, or assumes any legal responsibility for the accuracy, completeness, or usefulness of any information, apparatus, product, or process disclosed, or represents that its use would not infringe privately owned rights. Reference herein to any specific commercial product, process, or service by its trade name, trademark, manufacturer, or otherwise, does not necessarily constitute or imply its endorsement, recommendation, or favoring by the United States Government or any agency thereof, or The Regents of the University of California. The views and opinions of authors expressed herein do not necessarily state or reflect those of the United States Government or any agency thereof or The Regents of the University of California

Acknowledgements

This work was supported by the Assistant Secretary for Energy Efficiency and Renewable Energy, Building Technologies Program, of the U.S. Department of Energy under Contract No. DE-AC02-05CH11231.

The authors gratefully acknowledge Jason Hartke, Holly Carr, and Cindy Zhu at the U.S. Department of Energy for their sponsorship and guidance of this project. The authors thank the project team members who provided input during the course of this effort, including the following: Philip Coleman, Jeff Deason and Tianzhen Hong at LBNL; Robert Sahadi and Lenny Kolstad at the Institute for Market Transformation.

TABLE OF CONTENTS

- Abstract 4**
- 1 Introduction 5**
- 2 Default Risk Model with Energy Factors 7**
 - 2.1 Mortgage and Energy Data 8
 - 2.2 Model Form 10
- 3 Energy Use Metrics 12**
 - 3.1 Energy Use Intensity 12
 - 3.2 Energy Star Score 12
- 4 Electricity Price Gap 13**
- 5 Results: Default Risk Model 16**
 - 5.1 Summary Statistics 17
 - 5.2 Source EUI and Default Risk 19
 - 5.3 Site EUI and Default Risk 20
 - 5.4 Energy Star Score and Default Risk 21
- 6 Impact of Building Asset and Operational Characteristics on Default Risk..... 23**
 - 6.1 Simulation Models 24
 - 6.2 Variations in Operational Parameters 25
 - 6.3 Variations Due to Weather 31
 - 6.4 Impact of Source EUI Variations on Default Risk 32
- 7 Conclusions 33**
- 8 References 33**

Abstract

This is a first study of the effects of building-level energy consumption and the time-series risk of the energy pricing on the default risk of commercial mortgages. We apply measures of energy consumption using information on building-level source energy use intensity (EUI) and site EUI obtained from a unique data set that merges the building-level data collected through the benchmarking ordinances of Boston, Chicago, Minneapolis, New York, Philadelphia, and Washington, DC with origination and performance data for commercial mortgages that have been securitized into commercial mortgage backed securities. We develop a unique measure of energy price risk called the electricity price gap, computed as the difference between realized and expected electricity prices since the date of loan origination. We find that building-level source EUI and the electricity price gap are statistically and economically associated with commercial mortgage defaults. Using building energy simulations, we find that building asset characteristics and operational practices that affect source EUI have very important effects on the likelihood of default. Overall these results suggest that building-level energy efficiency and energy price risk do move the needle on default risk. Since commercial real estate investors are the residual claimants on this risk exposure, these results show the potential importance of accounting for energy efficiency and price risk as part of the loan risk assessment process in new mortgage originations.

1 Introduction

The U.S. commercial real estate mortgage market is very large and default is the primary risk for commercial mortgage investors.¹ As is well known, commercial mortgage default is usually triggered by reductions in commercial real estate values either due to the loss of tenants or to significant reductions in the net operating income (NOI) generated by the buildings. Given the importance of net operating income to building performance, NOI is also an important determinant of the two primary commercial mortgage underwriting metrics: the loan to value ratio and the debt service coverage ratio.² Surprisingly, recent findings from a Department of Energy scoping study indicate that commercial real estate underwriters typically do not consider the energy efficiency or the energy use profile of commercial real estate when evaluating the default risk of new loan applications (Mathew et al. 2016). Even though it is known that energy expenses comprise on average 30% of operating cost and that energy costs are volatile (Jaffee et al. 2013a, BOMA 2009), mortgage underwriters usually do not have access to information on building-specific energy use in the appraisal, the pro forma, or the engineering reports for buildings. As a result, commercial mortgage lenders generally subscribe to the idea that the energy inefficiency of real estate assets is not a sufficiently important cause of commercial mortgage default to warrant the additional cost of its evaluation--that is, lenders do not believe that energy efficiency can “move the needle” on default incidence.

Counter to this view, there is a recent literature that has considered the effect of green building labels on commercial real estate values (see, for example: Eichholtz et al. 2010; Fuerst and McAllister 2011; Eichholtz et al. 2013; Jaffee et al. 2013b; Deng and Wu 2014) and has found a strong association between the presence of an energy efficiency label, such as Energy Star or LEED Certification, and higher commercial building values and rents. However, the hedonic specifications (see, Rosen 1974) used in these studies often do not consider the buildings' energy costs. The cause of this benefit could either be associated with real energy efficiency of the building, although this is usually unmeasured, or it could be due to the “plaque-in-the-lobby-effect” or other labeling-related attributes (See, for example the label of an “architect designed building,” as in Vandell and Lane (1989)).

Another recent literature that more directly addresses the relationship between the energy efficiency of commercial real estate and mortgage default has applied reduced-form hazard models of commercial mortgage default that include indicator variables for whether or not buildings collateralizing the mortgages have an Energy Star or LEED Certification label (see, for example: Seslen and Wheaton 2010; An, Deng, Nichols, and Sanders 2013; An and Pivo 2015). Here again, these studies do not consider the operating (particularly energy) costs of the

¹ In 2015, the total outstanding stock of commercial mortgages was \$2.5 trillion, according to the Federal Reserve Statistical Release, Financial Accounts of the United States, Flow of Funds, Balance Sheets, and Integrated Macroeconomic Accounts, U.S. Flow of Funds, <https://www.federalreserve.gov/releases/z1/20160916/z1.pdf>

² The loan to value ratio is the ratio of the outstanding balance on the loan to the total building value where total building value is the discounted present value of NOI over an infinite horizon. The debt service coverage ratio is the ratio of the net operating income over the debt service.

buildings. The presence of the labels might be expected to have a positive effect on the probability of default but the cause is indeterminate. To date, there is also no supporting empirical literature on the correlations between labels and the probability of commercial mortgage default.

A second strand of the empirical mortgage default literature analyzes commercial mortgage default using structural option pricing models. Option pricing models account for the underlying macro-determinants of option exercise, interest rates, and NOI dynamics, often with frictions (see, for example: Schwartz and Torous 1989; Titman and Torous 1989; Stanton and Wallace 2014). This literature was extended by Jaffee et al. (2013a) to explicitly consider a four-factor option valuation framework that included the cost dynamics of both natural gas and electricity in addition to interest rates and rents. Their model explicitly accounts for the energy price and consumption risk of loans on individual office buildings in terms of the energy efficiency of the buildings and the energy cost characteristics of their locations. They find that not accounting for the ex ante energy consumption of a commercial office building leads to a 5% over-pricing of mortgages (due to the under-prediction of default). One limitation of the paper was the lack of information on actual building-level energy efficiency. Instead, the dynamics were calibrated to the price dynamics of natural gas and electricity futures and forwards for the regional hubs and to loan-level mortgage default performance within those hubs. The pricing results were then based on simulations for the probability of default for mortgages collateralized by buildings of a given profile within the regions. A second limitation with the empirical work was that it was based on the wholesale pricing of electricity and natural gas during a period of time in which the commercial building adoption rates for competitive sources of electricity supply were poorly understood and state-level energy retail choice deregulation was rather new (so that uptake among owners was likely very low).

The purpose of this report is to evaluate the impact of actual energy efficiency and energy cost on the default performance of securitized commercial mortgages between 2000 and 2016. The study uses building-level energy efficiency metrics obtained from six cities in the U.S. that implemented the energy efficiency benchmarking of commercial real estate. Using the addresses of each building in the benchmarking city samples, we construct an analysis data set in two further steps. To obtain the appropriate locational marginal price of electricity for the building, we first merge the benchmark buildings to the independent system operator (ISO) that sets wholesale prices for the building. To obtain the mortgage data for these buildings, we search a commercial mortgage data set, obtained from Trepp, that records the mortgage contracting structure, additional property characteristics, and the default performance of the mortgages over time. Thus, our merged dataset allows for an analysis of commercial mortgage default that explicitly considers the energy efficiency of the building, the mortgage contracting and performance structure, and the location-specific cost of energy to the mortgage borrower. Our analysis is also unique because it takes advantage of the data now being generated from the benchmarking cities. These data are especially advantageous because they include information on three different important energy metrics that are used by engineers to gauge the energy efficiency of commercial buildings: two measures of energy use intensity (EUI) – site EUI and source EUI; and the Energy Star score.

The paper is organized as follows. Section 2 presents our modeling approach and data-merging strategy for the mortgage and commercial real estate data that are used in our analysis. Section 3 presents the energy use metrics in more detail. Section 4 presents our measure of the energy pricing risk associated with the locational marginal prices of electricity in ISO/RTO regions. In Section 5, we present our empirical mortgage default analysis controlling for the energy efficiency profile of the building and the locational cost of energy. We find a strong association between energy factors and default. In Section 6, we do a scenario analysis showing the impacts of building asset and operational characteristics on default risk. Section 7 concludes.

2 Default Risk Model with Energy Factors

Our study is designed to use the same class of empirical mortgage default models, usually logistic regression models that are used in the Dodd Frank Act Stress Testing (DFAST) environment. Our analysis takes advantage of the growing rates of adoption on the part of commercial real estate building managers to competitively source their energy consumption. Beginning in the late 1990's, a new restructured energy market was introduced in a number of states allowing large industrial and commercial energy consumers to contract their demands from independent service providers (see More and Kirsch 2013), offering more flexible and competitive pricing structures than those offered by the traditional utility companies. Typically, these service providers adopt a strategy of aggregating the demand of individual customers, procuring energy directly from the wholesale markets, and employing the existing futures, forward, and options markets of electricity and natural gas for managing the energy price risks from their operations. They offer a whole spectrum of pricing structures to their customers, ranging from a fixed price for the term of the supply contract to hourly variable rates indexed from the ISO or regional transmission organization (RTO) locational marginal price. In a fixed price structure the provider needs to bear the energy price risk when procuring energy in the wholesale markets, and would charge a premium relative to customers using a dynamic pricing rate (i.e., one that is responsive to the underlying wholesale market). As expected, retail markets' deregulation created incentives for large energy consumers to adopt pricing structures that reduce energy costs, such as a variety of dynamic pricing rates, and to respond to price signals by adjusting their demand. The overall effect is that energy price fluctuations experienced by some large industrial and commercial consumers now reflect those of the wholesale markets.

As shown in Figure 1, the rates of industrial and commercial real estate adoption of these more competitive supply sources for electricity are as high as 80 – 90% in Connecticut, DC, Illinois, Maine, Maryland, New York, Ohio, Pennsylvania, Rhode Island and Texas. Other states that have a 50% adoption rate include Delaware, Montana, New Hampshire, New Jersey, whereas Massachusetts has about a 20% adoption rate. Four other states, including California, suspended retail choice for residential customers, while still allowing large industrial and commercial customers to choose their supplies. Overall, for the fourteen jurisdictions shown in Figure 1, 44% of 37.8 million customers took service from competitive providers as opposed to regulated utilities. With this evolution in the energy supply markets it is now reasonable to view

wholesale pricing as a proxy – albeit with a time lag - for the energy pricing actually faced by commercial real estate building owners.

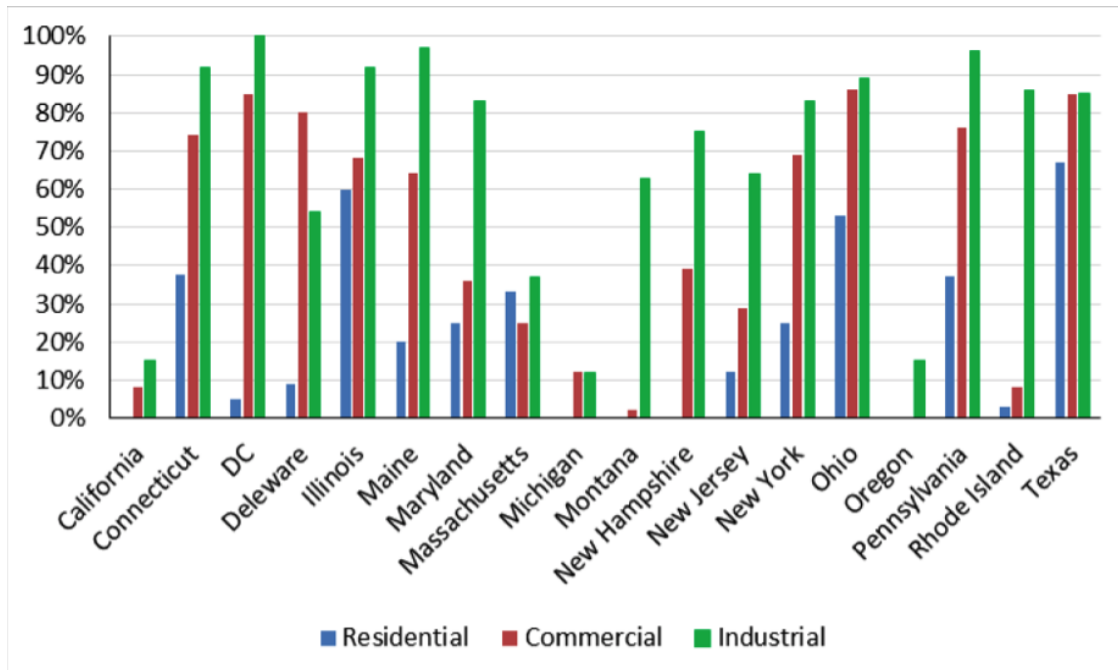

Figure 1. Percentage of building users by type that use a competitive supply source for electricity service provision in 2014. Source: More and Kirsch (2013)

2.1 Mortgage and Energy Data

Obtaining large data sets with standardized energy efficiency metrics that can be compared across building types and geographic regions is a key challenge for studies of commercial real estate energy efficiency. The energy efficiency data problem for this study is even more demanding because the ideal data for our purposes would include time-variant pricing and consumption data for specific buildings, loan-level performance and contracting data for the same buildings, and a representative sample of buildings across market segments. An additional significant challenge is the lack of specific energy tariff data for individual buildings.

Our primary loan-level origination and performance data and our building-level energy efficiency data sets were obtained respectively from Trepp, LLC and through the benchmarking ordinances of Boston, Chicago, Minneapolis, New York City, Philadelphia, and Washington, DC.

Trepp data

We estimate the default probability models using a sample of loans on commercial office buildings that were originated between 2000 and 2012. These data were obtained from Trepp

LLC's loan-level origination and performance data and include information on the structure of the mortgage contract, property and leasehold characteristics, and monthly performance records. Trepp obtains its loan-level origination and performance information from monthly master servicers' reports using a standardized reporting format defined in the Commercial Real Estate Finance Council's (CREFC) Investor Reporter Package (IRP). The total Trepp data set includes about ten million monthly observations of loan performance information, including the status of the loan, such as prepaid, delinquent, foreclosed or current, in each month. It also contains updated loan balance, debt service coverage ratio, occupancy rate and loss information, if reported by the servicer, as well as detailed information on the contractual structure of the loan. The nearly ten million loan performance records in our database cover 90,000 commercial mortgages. All the loans that we consider are for single properties so each loan can be tied to a specific location for analysis of locational features. One important limitation is the lack of data on net vs. gross leases and our analysis therefore did not consider impact of lease type on default risk.

Our measure of loan default is defined to be when the loan is at least 60 days delinquent, in bankruptcy, real estate owned (REO),³ or in foreclosure. We use a default indicator variable that is one on the first date that Trepp records the loan to have entered into these states.

Benchmarking data

The energy consumption data used in this study were obtained under the data collection efforts mandated by energy benchmarking ordinances in Boston⁴, Chicago⁵, Minneapolis⁶, New York City⁷, Philadelphia⁸, and Washington, DC.⁹ Although each city has its own local ordinance, the common requirements are that all privately owned properties with individual buildings of more than 50,000 square feet and properties with multiple buildings with a combined gross floor area of more than 100,000 square feet must annually measure and report their energy and water use to their respective city building departments. New York first collected data under its ordinance in 2011, Chicago, Boston, Philadelphia, and Minneapolis' ordinances have been in place since 2013, and Washington, DC's was part of the Clean and Affordable Energy Act of 2008. As discussed previously, the building-level data from the benchmarking ordinances include the building address, site EUI, source EUI, and Energy Star score. These metrics are described further in Section 3.

³ REO, Real Estate Owned, occurs when the lender exercises their right to take back the loan due to foreclosure and holds the underlying real estate value on their balance sheet in lieu of the loan balance.

⁴ Building Energy Reporting and Disclosure Ordinance (BERDO), url: <https://www.cityofboston.gov/eeos/reporting/>.

⁵ Chicago Energy Benchmarking Ordinance, url: <https://www.burnhamnationwide.com/final-review-blog/chicago-energy-benchmarking-ordinance-update>.

⁶ Minneapolis Building Benchmarking Ordinance 47.190

<http://www.ci.minneapolis.mn.us/environment/energy/WCMS1P-120169>.

⁷ New York Local Law LL84, <http://www.nyc.gov/html/gbee/html/plan/ll84.shtml>.

⁸ Philadelphia Building Energy Benchmarking Ordinance, url: <https://www.wegowise.com/compliance/philadelphia-building-energy-benchmarking-ordinance>.

⁹ Clean and Affordable Energy Act of 2008, <https://www.google.com/webhp?sourceid=chrome-instant&ion=1&espv=2&ie=UTF-8#q=Washington+DC+energy+benchmarking+ordinance>

We took the data published by the cities and then cleaned them using the data-cleaning rules of the DOE Building Performance Database (BPD). The cleaned version of these benchmarking data were used for this analysis.¹⁰ Overall, there were about 10,000 observations in the benchmarking data. We focus on the commercial office and retail property types for this study.¹¹

2.2 Model Form

As shown in Figure 2 our empirical reduced-form model of mortgage default requires the integration of multiple types of data. As shown in the far left-hand side of the schematic, we started with the cleansed version of the benchmarking disclosure data. As noted earlier, the benchmarking data provide two important measures of energy use intensity (EUI), the site EUI and source EUI, as well as the Energy Star score for each building. These are explicit measures of the relative energy consumption of each building. If energy efficiency actually moves the needle on default it must be that the more efficient buildings are less likely to default.

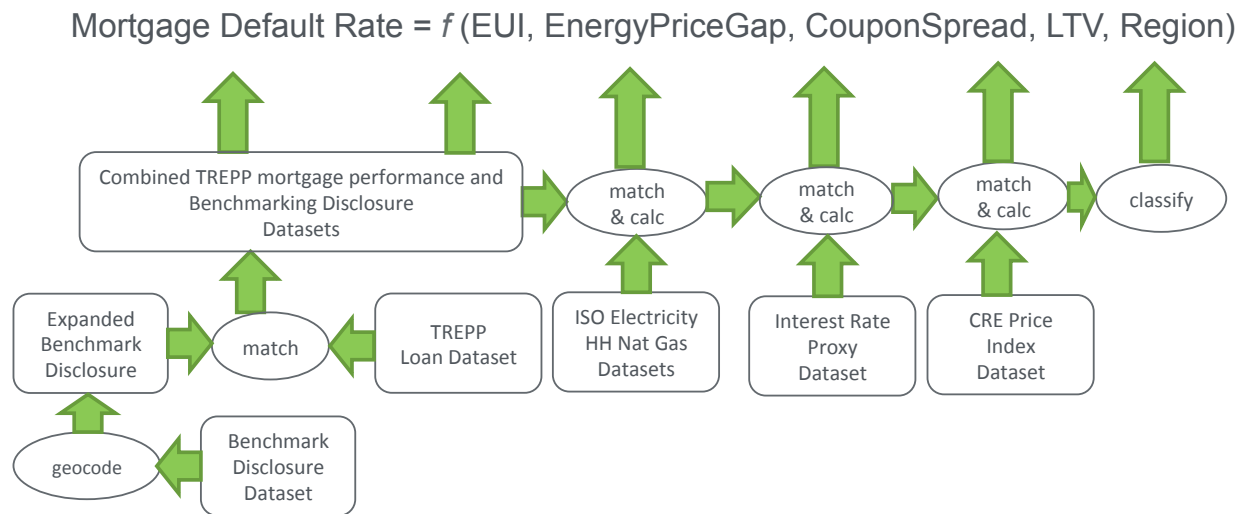

Figure 2. Data construction for empirical default hazard models.

Following the data set construction sequence outlined in Figure 2, we geo-coded the building-level benchmarking disclosure data and merged them with loan-level commercial mortgage origination and performance data obtained from Trepp LLC. The Trepp data provide information on loans that were securitized into the commercial mortgage backed securities (CMBS) market. These loans tend to be larger on average than commercial mortgages that are retained on bank balance sheets (see, for example, Ghent and Valkanov, 2015). This matching process gives us a data set with measures of energy efficiency at the building level, information on the loan

¹⁰ See, <https://bpd.lbl.gov/> for the BPD and <https://energy.gov/eere/buildings/downloads/data-preparation-process-buildings-performance-database> for the data cleansing rules.

¹¹ We find that the measures on a given building do not vary importantly over time, so we use the 2014 data as a proxy for the building's energy consumption

contracts, the leasehold structure of the building, the time-series performance of the loan, as well as property value and characteristics.

Jaffee et al. (2013a) established, in a structural model, that both energy price and consumption are important determinants of mortgage default. Building consumption and its volatility are determined by a building's characteristics (e.g., its envelope, HVAC and lighting systems), its operations, and weather conditions. Especially in deregulated markets, energy consumption can also be determined by energy prices. Following the option pricing literature (see, for example Kau and Keenan 1995; Schwartz and Torous 1989; Titman and Torous 1989; Stanton and Wallace 2014), default options become more valuable with volatility and since the default option is owned by the building owner we would expect more commercial mortgage default in more costly and volatile energy supply markets. In our reduced form model, energy efficiency (source EUI, site EUI and Energy Star score) and wholesale energy prices are proxies for the energy consumption and price risk of commercial buildings, respectively.

The next step in the data construction process is to assign each mortgage in the matched loan and benchmarked building data set with a proxy reflecting the actual energy cost of the building. More specifically, we use the reported monthly average ISO/RTO zonal price for the load region where the commercial property is located. As will be discussed below in Section 4, our proxy for building energy prices is the wholesale market locational energy prices, using a new measure that we call the "*electricity price gap*." This measure is intended to capture the energy price risk at the geographic location of the building. We map all of our buildings into their respective ISO zonal price region and calculate for each loan the average monthly on-peak locational marginal price.

The final stage of the data construction process, as shown in Figure 2, is to add other important macro-economic determinants of mortgage defaults such as a monthly time series of interest rates. We use this interest rate data to construct a measure of the coupon gap, the difference between the current monthly interest rate and the mortgage contract rate. This measure is commonly included in mortgage default analyses and can be viewed as either a measure of the moneyness of the prepayment option or as the relative costliness of the current mortgage. Depending on the channel the sign on this factor could be either positively or negatively associated with default. Similarly, we account for the buildings' prices with the loan-to-value (LTV) ratio at origination, which is a well-populated loan characteristic in the data.¹²

¹² Some loans in the Trepp data have time-varying LTV ratios but we found both a great deal of missing data and suspiciously static LTVs, so we chose to use the origination LTV as a proxy.

3 Energy Use Metrics

3.1 Energy Use Intensity

A key feature of our study is to have standardized measures of the annual energy consumption per unit area, expressed in kBtu per square foot. The measures were obtained from the building-level benchmarking data. The first measure of energy use intensity (EUI) is site EUI, which measures the amount of heat and electricity consumed per square foot as reflected in the building utility bills. The second measure, the source EUI, measures the total amount of raw fuel that is required to operate the building per square foot including all transmission, delivery and production losses.¹³

Source EUI is considered the “gold standard” measure of energy efficiency because it provides the most equitable assessment of building-level energy efficiency. Billed site energy use is the primary component of the site EUI and energy billing structures reflect a combination of primary energy (the raw fuel that is burned to create heat and electricity) and secondary energy (the purchased energy product created from a raw fuel). Units of primary and secondary energy consumed at a site are not directly comparable because one represents a raw fuel while the other represents a converted fuel within the region. For this reason, site EUI does not provide an equivalent thermodynamic assessment for buildings with different fuel mixes and system efficiencies. This is especially pronounced in the case of fossil fuel-generated electricity, which generally requires about three units of raw fuel for every unit of electricity produced.

In contrast, source EUI incorporates all production, transmission, and delivery losses, which accounts for all primary fuel consumption and enables a complete assessment of energy efficiency in a building. Source energy traces the heat and electricity requirements of the building back to the raw fuel input, thereby accounting for any losses and enabling a complete thermodynamic assessment. Higher source EUI and higher site EUIs both indicate less efficient buildings, so we would expect a positive association between these energy efficiency measures and the likelihood of commercial mortgage default. It is also worth noting that in general, source EUI is considered to be better than site EUI as a proxy for energy cost, which is the metric that is directly used in NOI calculations.

3.2 Energy Star Score

The EPA Energy Star score is a rating algorithm based on building characteristics and utility bills that is scaled between 1 and 100, with 100 representing the highest level of energy efficiency.¹⁴ A score of 50 represents a median energy performance, while a score of greater than 75 may allow the building to be eligible for Energy Star certification. The goal of the Energy

¹³ See, <https://www.energystar.gov/buildings/facility-owners-and-managers/existing-buildings/use-portfolio-manager/understand-metrics/difference>

¹⁴ See, <https://www.energystar.gov/buildings/facility-owners-and-managers/existing-buildings/use-portfolio-manager/understand-metrics/how-1-100>

Star program is to provide comparisons of building energy efficiency relative to a national peer group. For this reason the index is constructed using a national-level source-site conversion ratio. The use of a single national source-site conversion standardizes the Energy Star score such that although two buildings with equivalent energy efficiency in two different regions may have different absolute energy consumption, perhaps owing to weather conditions, the Energy Star score will be equivalent. Since higher scores imply more efficient buildings, we would expect a negative and statistically significant association between the Energy Star score and the likelihood of commercial mortgage default.

4 Electricity Price Gap

Another key metric for empirical analyses of commercial real estate energy efficiency is actual energy prices. In addition, another factor is the relative variance of realized energy prices from the prices that would have been forecast at the time the loan was originated. We measure the difference between forecasted and actual energy costs over the mortgage holding period to provide a measure of building-specific electricity price risk. We term this the electricity price gap. We focus on electricity prices because across all commercial buildings in the U.S., electricity accounts for 62% of energy use.¹⁵

Figure 3 shows the geographic territories covered by the independent system operators (ISOs) in North America. ISOs serve as arms-length, third-party pricing organizations for utility companies and independent power generators, along with their primary role of ensuring that, at any point in time, the power grid (power plants, substations, and transmission lines) is dispatched at its minimal possible cost while guaranteeing system reliability. The ISO creates a competitive market for power generation by giving no preference on dispatching a utility-owned generator over a competitive generator. When planning and executing the system dispatch, ISOs also conduct the day-ahead electricity market, and the real-time (or “spot”) market respectively.

¹⁵ See, Energy Star Portfolio Manager, Technical Reference, <https://portfoliomanager.energystar.gov/pdf/reference/ENERGY%20STAR%20Score.pdf>

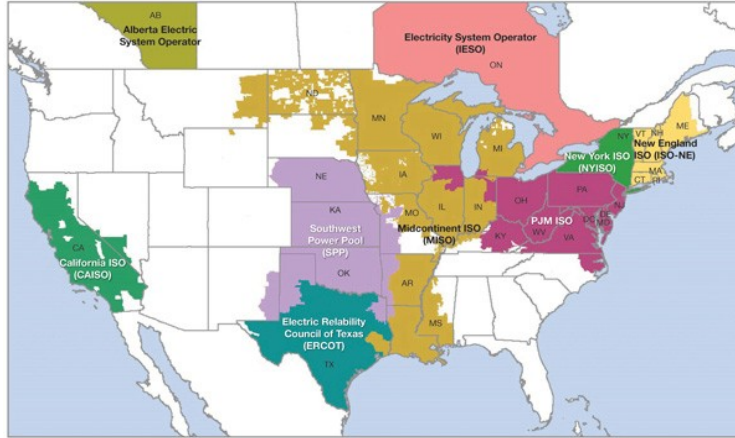

Figure 3. Independent System Operators in North America. Source: Federal Energy Regulatory Commission (FERC)

Most ISOs in the U.S. use a system called locational marginal pricing (LMP) to establish the price of energy in the wholesale electricity market. At each time interval (typically 15 minutes) the ISO optimizes the dispatch of generators and calculates a locational marginal price for each node in the power grid. Zonal LMPs are derived by averaging prices over nodes in a zone of interest for market participants, sometimes choosing nodes covered by an electric utility territory. These zonal prices also serve as a benchmark for settlements of financial transactions and contracts between market participants such as utilities, generators, and market makers. Figure 4 and Figure 5 show the zone maps for the New York ISO and PJM. Note that New York City falls into NYISO Zone J, while Chicago is within PJM's Commonwealth Edison (ComEd) zone.



Figure 4. New York ISO zone map.



Figure 5. PJM zone map.

Table 1 lists corresponding ISOs for the cities analyzed in our study, as well as the zonal LMPs that best reflect the electricity prices faced by the commercial real estate properties. Our study covers mortgages originated from 1999 through 2012. The ISOs' LMP time series for some

cities, however, do not go as far back as 1999. For the missing time periods, we use prices from the geographically closest ISO.

Table 1. Cities and zonal locational marginal prices

City	Primary Time Series			Alternative Time Series		
	ISO	ISO Zone	Start of time series	ISO	ISO Zone	Start of time series
Boston	NEISO	NEMASSBOST	2/1/2004	PJM	ZONE PPL	4/1/1999
D.C	PJM	PEPCO	4/1/1999			
Chicago	PJM	COMED	4/1/2005	PJM	AGGREGATE DPL NORTH	4/1/1999
Minneapolis	MISO	MINN.HUB	3/1/2006	PJM	AGGREGATE DPL NORTH	4/1/1999
New York	NYISO	Zone J	10/1/2000	PJM	ZONE JCPL	4/1/1999
Philadelphia	PJM	PECO	4/1/1999			

For our analysis, we first collected individual files with hourly locational marginal prices directly from the ISOs' websites. We then consolidated the data by calculating a time series of monthly average locational marginal prices for the on-peak hours.¹⁶ On-peak hours better reflect the time and days of the week when commercial buildings perform most of their business activities, and consequently when energy consumption is highest. The electricity price gap is computed by summing the deviations of a proxy for the realized monthly energy expenditures from a proxy for the "expected" monthly expenditures that we assume could have been anticipated by the borrower, and/or lenders, at the time of mortgage origination (Figure 6). Formally, the electricity price gap for a commercial mortgage within ISO zone k and originated at a time period t_0 is expressed as

$$pgap_k(t_0, t) = \sum_{s=t_0}^{s=t} lmp_k(s) - hlmp_{k, month(s)}(t_0),$$

where t is a time period defined at any distribution date over the observed mortgage payout period, $lmp_k(s)$ is the monthly average on-peak locational marginal price at zone k for the time period s , and $hlmp_k(t_0)$ is a 12-row vector holding constant the monthly average locational marginal prices as measured from the month and year of the mortgage origination date. This price vector is our proxy for the expected energy prices for each month of the year. The price difference at time s is calculated by indexing the corresponding historical monthly average price vector at origination $hlmp_k(t_0)$ by $month(s)$, [$s = 1, 2, \dots, 12$] and subtracting this value from $lmp_k(s)$.

A high cumulative price difference, or the gap, signals higher than expected total energy expenditures since mortgage inception all else equal. This creates a cumulative deficit in NOI,

¹⁶ On-peak hours are defined as non-holiday weekdays hours starting at 7:00:00 and ending at 22:59:59.

which in turn increases the likelihood of default. The electricity price gap depends on the region where the property resides, and both the time of mortgage origination and the history of the locational marginal prices after the mortgage origination. The gap will likely be positive if the mortgage origination happened at a time when energy prices were relatively low and not expected to rise much. Likewise, it will likely be negative if origination happens at a price peak. Finally, as a proxy, our measure of the electricity price gap summarizes the full history of electricity prices through the life of the mortgage. In a simple way, it capitalizes monthly cash flow variations related to electricity prices and in doing so, captures time dependencies during the life of the mortgage that may influence mortgage delinquency and default.

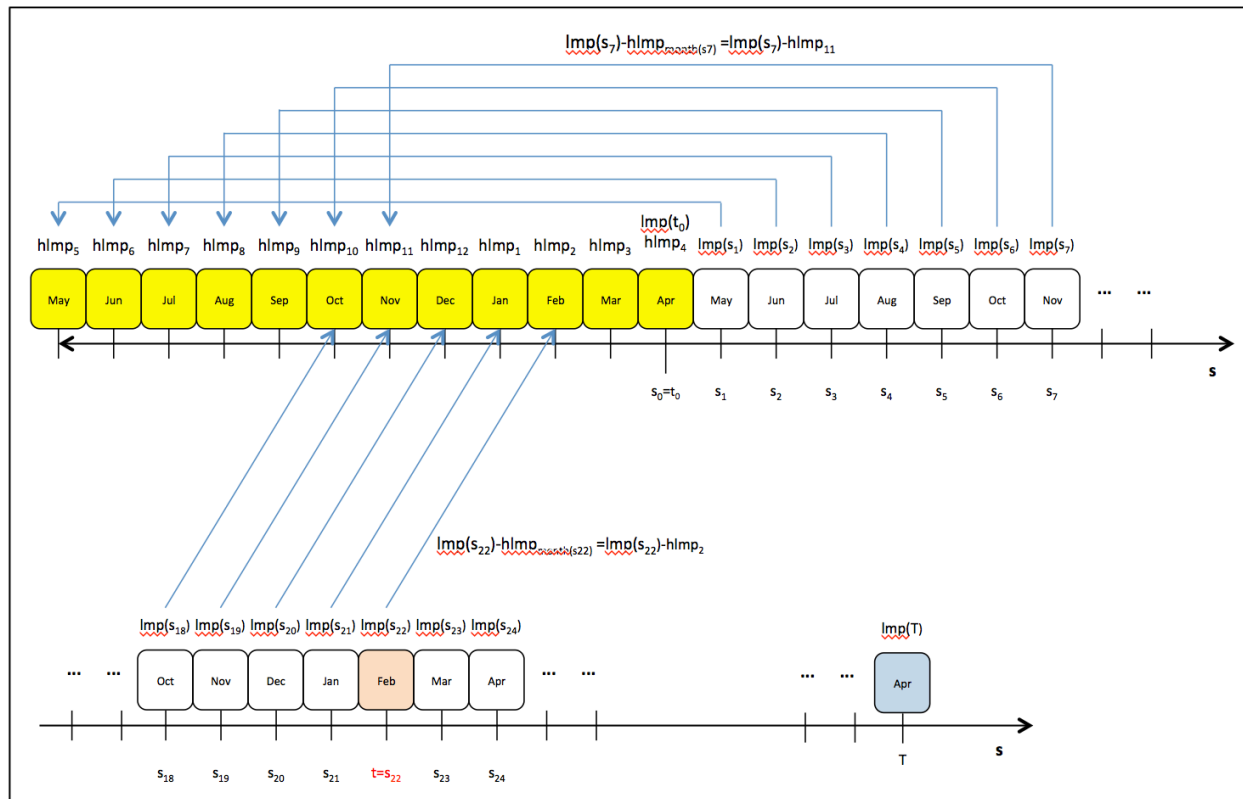

Figure 6. Schematic for the electricity price gap

5 Results: Default Risk Model

We estimate two specifications to determine the degree of association between commercial loan default and energy efficiency. In both specifications, we are using a non-time-varying specification for estimating the default probabilities similar to the specification used in Schwartz and Torous (1989). We estimate both a linear probability model and a logistic regression model that controls for the underwriting characteristics of the loan at origination and for the macro-factors such as the spread between the coupon on the mortgage and the current 10-year Treasury rate, the site EUI, the source EUI, and the electricity price gap as measured for the loan at the time of default or at the end of the holding period, whichever comes first. This specification thus does not control for the hazard of default, the probability that the loan defaults

on a given month given that it has survived up to that month, because only the 10-year Treasury rate and the electricity price gap are truly time-varying. All of the other co-variates, including the site and source EUI, do not really evolve over the analysis period. Use of a hazard specification would also require a further modification of the functional form of the baseline hazard since the balloon rollover date induces a nonlinear increase in the hazard at the balloon due date. To avoid imposing functional form restrictions we estimate the more robust linear probability and logistic regression models.¹⁷

5.1 Summary Statistics

The intersection of the Trepp securitized commercial mortgage data and the benchmark data was rather small, with only about 1900 observations found to be common across the two data sets. The likely reason for this is that the Trepp loans, on average, are for larger real estate assets and the property types are heavily skewed toward office, industrial, retail, and multi-family, whereas the benchmark data include many government and institutionally owned buildings such as schools. Given the small number of multi-family properties in our merged data set, we focus on the office properties so that the sample is as large and standardized as possible. We have properties from all six cities; however, because the benchmark data collection effort started earlier in New York and Washington, DC, there is somewhat more representation in the sample for those two cities than the other four.

We report the summary statistics for both the full merged sample and the sub-sample of office/retail properties. Table 2 and Table 3 present the summary statistics for the full and office samples respectively. They also report summary statistics for the loans that are current in their payments and for loans that are defaulted. Loans are designated as defaulted if they were identified by TREPP as 60 plus days delinquent loans, or loans that were in bankruptcy, REO, or foreclosure. As shown in both the full sample and the office sub-sample, the defaulting loans tend to be larger, have consistently higher source and site EUIs, as well as lower Energy Star scores. They also tend to have shorter due dates for the balloon payment on the loan¹⁸.

Surprisingly, the underwriting criteria on the loans at origination, such as the loan-to-value ratios, are quite similar so these loans do not appear to be the result of riskier underwriting. A second surprising result is that the unconditional mean electricity price gap is positive for the surviving loans, whereas it is negative for the defaulted loans implying that on average they experienced prolonged periods where the realized locational marginal prices for electricity in their ISO region fell below the historical levels. However, the standard deviations of the electricity price gap are large.

¹⁷ Within the Dodd Frank Act Stress Testing (DFAST) framework, the logistic regression model is the most widely used specification to estimate of the probability of commercial mortgage default.

¹⁸ Commercial mortgages tend to amortize over a different horizon than the date that their full principal balance is due and payable in full. This structure reduces the installment payments on the loan but it increases its risk because the full balance of the loan must be paid sooner. Commercial mortgage therefore face a known increase in risk at the time that the balloon is due. They must either sell the building or refinance on the balloon date or risk defaulting on the remaining principal.

Table 2. Summary Statistics for Merged TREPP and Benchmarking data: Full Sample

	No. of obs.	Mean	Std. Dev	Minimum	Maximum
<i>Default = 0</i>					
Source EUI	873	158.06	61.88	5.3	309.6
Site EUI	922	79.93	28.98	21.56	145.17
Energy Star Score	762	66.927	23.416	1	100
Loan-to-Value Ratio (%)	920	44.18	27.39	0.3	89.87
Origination Contract Rate (%)	907	6.03	1.01	2.09	9.2
Percentage Leased at Origination (%)	674	94.34	7.87	57.8	100
Rentable Square Footage	471	518,428.28	559,901.66	3,650	4,150,000
Origination Net Operation Income (\$000)	862	6,622.82	12,506.34	171.58	118617.23
Time to Maturity on Balloon (months)	922	118.10	32.95	24	240
Origination Loan Balance (\$ Millions)	897	35.74	61.61	0.5	806
Electricity Price Gap	922	136.55	2,263.61	-5,095.26	5,349.06
<i>Default = 1</i>					
Source EUI	74	197.91	63.67	55.1	304.7
Site EUI	80	86.56	28.98	21.00	289.24
Energy Star Score	66	62.67	24.22	7	100
Loan-to-Value Ratio (%)	78	66.99	14.13	5.3	80.99
Origination Contract Rate (%)	79	6.16	1.05	3.59	8.84
Percentage Leased at Origination (%)	77	93.44	8.63	66.5	100
Rentable Square Footage	80	608,004.85	515,287.87	51,110	1,560,000
Origination Net Operation Income (\$000)	75	20,114.05	36,697.63	279.121	118617.23
Time to Maturity on Balloon (months)	80	100.38	33.89	36	144
Origination Loan Balance (\$ Millions)	63	58.05	35.02	33	180
Electricity Price Gap	80	-113.83	1,400.53	-3,630.24	4,738.01

Table 3. Summary Statistics for Merged TREPP and Benchmarking Data: Office, Mixed Use, Retail Properties

	No. of obs.	Mean	Std. Dev	Minimum	Maximum
<i>Default = 0</i>					
Source EUI	434	190.40	58.93	5.3	309.6
Site EUI	471	79.75	31.45	1.2	289
Energy Star Score	434	71.62	18.79	2.80	100
Loan-to-Value Ratio (%)	469	61.78	15.38	7.3	89.87
Origination Contract Rate (%)	460	5.99	1.10	2.09	8.88
Percentage Leased at Origination (%)	454	94.06	7.55	59.3	100
Rentable Square Footage	471	518,428.28	559,901.66	3,650	4,150,000
Origination Net Operation Income (\$000)	432	10,436.86	16,402.73	177.989	118617.23
Time to Maturity on Balloon (months)	471	110.60	28.98	24	240
Origination Loan Balance (\$ Millions)	455	59.24	75.06	1.1	806
Electricity Price Gap	471	54.88	2,155.36	-5,007.82	4,199.76
<i>Default = 1</i>					
Source EUI	58	209.29	61.16	55.10	304.70
Site EUI	64	85.68	29.85	21.40	145.17
Energy Star Score	51	67.92	24.23	13.00	100
Loan-to-Value Ratio (%)	63	69.03	11.04	35.3	80.99
Origination Contract Rate (%)	63	6.12	1.04	3.59	8.84
Percentage Leased at Origination (%)	63	93.60	8.23	67.4	100
Rentable Square Footage	64	692,870.69	529,595.88	54,800	1,560,000
Origination Net Operation Income (\$000)	60	20,114.05	36,697.63	279.121	118617.23
Time to Maturity on Balloon (months)	64	98.72	33.89	36	144
Origination Loan Balance (\$ Millions)	63	58.05	54.05	0.77	258.48
Electricity Price Gap	64	-22.12	1,442.3	-2,842.93	4,738.01

5.2 Source EUI and Default Risk

The specification for our preferred measure of energy efficiency, source EUI, is reported in Table 4. As shown, despite the property heterogeneity in the full sample with fixed effects for the origination year shows the log source EUI to be positive and statistically significantly associated with the likelihood of default. Energy efficiency (i.e. lower source EUI) appears to be an important mitigating factor for default and as shown for the full sample a 1% increase in log source EUI is associated with a 4% increase in default, whereas for the office sample a 1% increase in the log of source EUI is associated with a 7% increase in default. Similarly, the electricity price gap also has a positive and statistically significant association with the default of commercial mortgages, suggesting that properties that are exposed to more energy cost risk – all else being equal -- are more likely to default, although as shown a 1% increase in this risk is associated with only a .15 basis point increase in default in both the full and office samples. All of the other underwriting covariates also have the expected sign. The longer the time to the balloon, the lower the default risk, and the higher the original loan-to-value ratio, the higher the default risk. Interestingly, comparing the fully saturated model with the model that is only a function of log source EUI suggests that introducing the electricity price gap as a measure of price risk reduces the positive effect of efficiency on default but it remains a statistically and economically significant variable.

The results for the office-only sample are similar both for the linear probability of mortgage default and for the logistic regression model. Even in the smaller sample, the statistical and economic significance of the source EUI and the electricity price gap remain. As shown in the bottom segment of Table 4, the higher the source EUI (the more energy usage per square foot) the higher the likelihood of default. Similarly, the higher the electricity price gap (the larger the difference between the realized and the expected electricity prices since the loan origination), the higher the likelihood of default although the effect is economically small.

To our knowledge, these are the first reported empirical results strongly supporting an economic and statistical relationship between the energy efficiency of a building (controlling for the relative risk of electricity prices) and its default risk. Our evidence suggests that even with a relatively small sample (excepting the loans securitized through CMBS, which is a large and important market segment), building-level energy efficiency and local energy pricing risk are actuarial factors in the incidence of default. For this reason, since commercial real estate investors are the residual claimants on this risk exposure, these results show the importance of accounting for energy efficiency and locational price risk as part of the loan risk assessment process.

Table 4. Estimates for the Loan-level Default using Log Source EUI: Linear Probability Specification and Logistic Regression (Foreclosure or REO = 1)

<i>Full Sample</i>								
Linear Probability Specification	Coefficient Estimate	Standard Error	t test	Prob > t	Coefficient Estimate	Standard Error	t test	Prob > t
Intercept	-0.30784	0.0873	-3.53	0.0004	-0.20236	0.09907	-2.04	0.0414
Log Source EUI	0.07742	0.01742	4.44	< .0001	0.04022	0.01813	2.22	0.0267
Origination Loan-to-Value Ratio					0.00131	0.00035779	3.67	0.0003
Coupon Spread to 10 Yr. Treasury					0.00951	0.00994	0.96	0.3389
Electricity Price Gap					0.00001479	0.00000646	2.29	0.0222
Time to Maturity on Balloon					-0.00057645	0.00030711	-1.88	0.0608
Origination Year Fixed Effects	No				Yes			
R2	0.019				0.0859			
N	947				916			
<i>Office, Mixed Use and Retail Sample</i>								
Linear Probability Specification	Coefficient Estimate	Standard Error	t test	Prob > t	Coefficient Estimate	Standard Error	t test	Prob > t
Intercept	-0.19342	0.16448	-1.18	0.2402	-0.40444	0.18466	-2.19	0.029
Log Source EUI	0.06001	0.03159	1.9	0.058	0.07335	0.03129	2.34	0.0195
Origination Loan-to-Value Ratio					0.00258	0.00096055	2.69	0.0074
Coupon Spread to 10 Yr. Treasury					0.02188	0.01565	1.4	0.1628
Electricity Price Gap					0.00003483	0.00001188	2.93	0.0035
Time to Maturity on Balloon					-0.00189	0.00060375	-3.13	0.0018
Origination Year Fixed Effects	No				Yes			
R2	0.0005				0.1052			
N	492				473			
Logistic Regression	Coefficient Estimate	Standard Error	χ^2 test	Prob χ^2	Coefficient Estimate	Standard Error	χ^2 test	Prob χ^2
Intercept	-6.5488	2.3831	7.5519	0.006	-11.1449	2.8697	15.0825	0.0001
Log Source EUI	0.8653	0.45	3.6966	0.0545	1.1714	0.5005	5.4788	0.0192
Origination Loan-to-Value Ratio					0.0375	0.0132	8.0571	0.0045
Coupon Spread to 10 Yr. Treasury					0.2616	0.1898	1.8982	0.1683
Electricity Price Gap					0.000432	0.00016	7.2822	0.007
Time to Maturity on Balloon					-0.0182	0.00625	8.4477	0.0037
Origination Year Fixed Effects					Yes			
N	492				473			

5.3 Site EUI and Default Risk

As argued above, the site EUI measure of energy efficiency does not as clearly differentiate efficiencies from the grid and those associated with the building. Nevertheless, for completeness we report the results of estimating both the linear probability and the logistic regression for the full sample of buildings and for the sub-sample of office buildings. As shown in Table 5, as expected the results for site EUI are essentially the same although the level of statistical significance in the smaller office-only sample is somewhat reduced. The full sample results are reported in the upper third of the table. These results reinforce those found in the specification with the preferred source EUI measure. As shown, the signs of the site EUI and the electricity price gap remain unchanged from the earlier specification, although the magnitudes are somewhat reduced. The other underwriting covariates are similarly unaffected.

These results again suggest that the higher the site EUI (the more energy usage per square foot) the higher the likelihood of default, whereas now a 1% increase in log site EUI is associated with a 2.6% increase in default. Similarly, the higher the electricity price gap the higher the likelihood of default.

Table 5. Estimates for the Loan-level Default using Log Site EUI: Linear Probability Specification and Logistic Regression (Foreclosure or REO = 1)

<i>Full Sample</i>								
Linear Probability Specification	Coefficient Estimate	Standard Error	t test	Prob > t	Coefficient Estimate	Standard Error	t test	Prob > t
Intercept	-0.09342	0.07402	-1.26	0.2072	-0.08215	0.08728	-0.94	0.3468
Log Site EUI	0.02909	0.0169	1.72	0.0855	0.02605	0.0165	1.58	0.1147
Origination Loan-to-Value Ratio					0.00157	0.00033723	4.65	< .001
Coupon Spread to 10 Yr. Treasury					0.00214	0.01008	0.21	0.8322
Electricity Price Gap					0.00001583	0.00000652	2.43	0.0154
Time to Maturity on Balloon					-0.00065518	0.00031397	-2.09	0.0372
Origination Year Fixed Effects	No				Yes			
R ²	0.0769				0.0859			
N	1002				972			
<i>Office, Mixed Use and Retail Sample</i>								
Linear Probability Specification	Coefficient Estimate	Standard Error	t test	Prob > t	Coefficient Estimate	Standard Error	t test	Prob > t
Intercept	-0.05633	0.07404	-0.76	0.4469	-0.10734	0.08375	-1.28	0.2002
Log Site EUI	0.03169	0.01711	1.85	0.0644	0.02685	0.01658	1.62	0.1057
Origination Loan-to-Value Ratio					0.0015	0.00034821	4.31	< .0001
Coupon Spread to 10 Yr. Treasury					-0.00002364	0.00014793	-0.16	0.873
Electricity Price Gap					0.00001901	0.00000629	3.02	0.0026
Time to Maturity on Balloon					-0.00048188	0.00028264	-1.7	0.0885
Origination Year Fixed Effects	No				Yes			
R ²	002				0.0701			
N	535				516			
Logistic Regression	Coefficient Estimate	Standard Error	χ ² test	Prob χ ²	Coefficient Estimate	Standard Error	χ ² test	Prob χ ²
Intercept	-4.1543	1.4916	7.7571	0.0054	-7.1918	1.9212	14.0136	0.0002
Log Site EUI	0.4974	0.3397	2.1441	0.1431	0.6706	0.3602	3.4658	0.0627
Origination Loan-to-Value Ratio					0.0325	0.0127	6.5177	0.0107
Coupon Spread to 10 Yr. Treasury					-0.00306	0.00239	1.6482	0.1992
Electricity Price Gap					0.00051	0.00015	11.5985	0.0007
Time to Maturity on Balloon					-0.0116	0.00502	5.3588	0.0206
Origination Year Fixed Effects					Yes			
N	535				516			

5.4 Energy Star Score and Default Risk

In our final specification, reported in Table 6, we use the Energy Star score as our measure of building level energy efficiency. Recall that this measure is a relative ranking of a building's energy efficiency compared to the national population of buildings where 100 is the highest ranking, implying that the building is efficient, and 1 is the worst, implying that the building is not efficient. We again report estimates for both a linear probability model and a logistic regression for both the full sample of buildings (with the merged benchmarking and Trepp data) and the sub-sample of office buildings. Surprisingly, the Energy Star score is the least well reported efficiency measure in our data. Our results therefore suffer from a further reduction of power; however, the economic intuition appears unchanged.

For the full sample, the coefficients on the Energy Star score has the anticipated negative sign where a 1% increase in the energy star ranking implies a 7 basis point increase in default. The energy price gap has the anticipated positive sign indicating that a 1% increase in the energy price gap is associated with a .21 basis point increase in default. However, the Energy Star score is not statistically different from zero at the .05 significance level in the linear regression for the smaller sample, although it is statistically significant at standard levels in the logistic

regression. The electricity price gap is significantly different from zero at the .05 level for both data samples and in all three specifications, although the coefficient is small.

Overall, these results suggest that energy efficiency does “move the needle” on default incidence. Since underwriting in the mortgage market is based on actuarial predictions, these results are an important first step in assessing the ways in which energy efficiency metrics could be introduced into the commercial mortgage underwriting process. Requiring source EUI information for buildings, especially in the benchmark cities, would be a relatively straightforward and could easily be introduced into the pro forma data fields that lenders currently consider in standard underwriting processes. A second channel whereby the source EUI could be introduced is in the engineering report that is also typically required for large loan underwriting. Obtaining the electricity price gap forecasts is also a tractable data-gathering problem. Some states have their locational marginal prices reported on-line by ISO region. These data are updated continually by the ISOs. Thus, collecting and managing these data for sale to lending underwriters should be a rather straightforward service function that many existing data vendors could quite readily undertake.

Table 6. Estimates for the Loan-level Default using Level of Energy Star Score: Linear Probability Specification and Logistic Regression (Foreclosure or REO = 1)

<i>Full Sample</i>								
Linear Probability Specification	Coefficient Estimate	Standard Error	t test	Prob > t	Coefficient Estimate	Standard Error	t test	Prob > t
Intercept	0.11709	0.02825	4.15	< .0001	0.0685	0.05583	1.23	0.2202
Energy Star Score	-0.00056148	0.0004001	-1.4	0.1609	-0.00073838	0.00039119	-1.89	0.0595
Origination Loan-to-Value Ratio					0.00145	0.00039088	3.72	0.0002
Coupon Spread to 10 Yr. Treasury					-0.00002261	0.00015508	-0.15	0.8841
Electricity Price Gap					0.00002103	0.00000688	3.06	0.0023
Time to Maturity on Balloon					-0.00055819	0.00031273	-1.78	0.0747
Origination Year Fixed Effects	No				Yes			
R2	0.0019				0.067			
N	828				802			
<i>Office, Mixed Use and Retail Sample</i>								
<i>Linear Probability Specification</i>	Coefficient Estimate	Standard Error	t test	Prob > t	Coefficient Estimate	Standard Error	t test	Prob > t
Intercept	0.1865	0.05788	3.22	0.0014	0.18383	0.11046	1.66	0.1865
Energy Star Score	-0.00102	0.0007852	-1.3	0.1929	-0.00134	0.00077931	-1.72	-0.00102
Origination Loan-to-Value Ratio					0.00183	0.00099161	1.84	
Coupon Spread to 10 Yr. Treasury					-0.00028944	0.00020694	-1.4	
Electricity Price Gap					0.00004327	0.00001234	3.51	
Time to Maturity on Balloon					-0.00166	0.00053658	-3.09	
Origination Year Fixed Effects	No				Yes			No
R2	0.002				0.0701			
N	448				516			
<i>Logistic Regression</i>	Coefficient Estimate	Standard Error	χ^2 test	Prob χ^2	Coefficient Estimate	Standard Error	χ^2 test	Prob χ^2
Intercept	-1.3896	0.5231	7.0583	0.0079	-2.5141	1.3571	3.4319	0.0639
Energy Star Score	-0.00952	0.00733	1.6891	0.1937	-0.0148	0.0081	3.3318	0.068
Origination Loan-to-Value Ratio					0.0279	0.0139	4.0125	0.0452
Coupon Spread to 10 Yr. Treasury					-0.00301	0.00264	1.297	0.2548
Electricity Price Gap					0.000521	0.000164	10.1174	0.0015
Time to Maturity on Balloon					-0.0149	0.00572	6.7447	0.0094
Origination Year Fixed Effects					Yes			
N	499				433			

6 Impact of Building Asset and Operational Characteristics on Default Risk

Results from the default risk analysis as described in section 5 above demonstrate a statistically significant link between default risk and two key energy factors -- source EUI and electricity price gap -- albeit for a limited dataset, with some important limitations and caveats. From an underwriting perspective, the ensuing issue is to understand the default risk implications for individual loans, i.e., how does energy use and price in a specific building affect the default risk on its mortgage?

Energy use in any given building is a function of asset and operational characteristics.

- Asset characteristics in this context refer to the fixed elements of the building, such as walls, windows, HVAC equipment, light fixtures, etc. Most energy-related asset characteristics generally do not vary over the course of a mortgage term unless the building is renovated or retrofitted.
- Operational characteristics in this context refers to parameters that might very well vary over the course of the loan, such as occupant density, occupancy schedules, plug loads, lighting and HVAC equipment control settings, and weather.

Ideally, such an analysis would be done empirically with a data set that includes detailed building asset and operational characteristics for a large number of representative buildings. However such a data set does not exist and would be cost-prohibitive to assemble for a large enough sample.¹⁹

As an alternative, we chose to do scenario analysis using energy simulation. The purpose of this scenario analysis was to analyze the impact of both asset and operational characteristics on energy use and therefore default risk. We used the EnergyPlus building energy simulation software²⁰ to model the range of source EUI variations attributable to various asset and operational characteristics and their combinations. While such energy simulations are not as useful for determining *actual* energy use, they are very useful for estimating the *relative* impact of changes in asset and operational characteristics. These relative changes in source EUI can then be used to determine the relative impact on default risk using the regression coefficients from the empirical default risk model described above.

In the remainder of this section we describe the following:

- The energy simulation models
- Variations in source EUI due to operational parameters
- Variations in source EUI due to year-to-year weather variation
- Variations in default risk due to asset and operational characteristics.

¹⁹ Over five years of experience with data collection for the DOE Building Performance Database has shown that asset and operational characteristics are not routinely collected and compiled in a consistent manner.

²⁰ <https://energyplus.net/>

6.1 Simulation Models

We developed energy models representing a large office building in two different climate zones, for three different asset efficiency levels, as shown in Table 7. The high asset efficiency model generally conforms to ASHRAE Standard 90.1-2013. The medium asset efficiency model generally conforms to ASHRAE 90.1-2004. The low asset efficiency model is intended to represent a building constructed before 1980 but with lighting and HVAC retrofitted. Therefore the only difference between medium and low asset efficiency is the window and wall construction. In all cases, we used ASHRAE 90.1-2013 assumptions for plug loads, occupancy levels, and lighting. As a sensitivity test, we also modeled a medium-size office building for one climate zone. The approach we used can be extended to other building types and locations, but that was beyond the scope of this illustrative scenario analysis.

Table 7. Asset efficiency levels modeled for large office buildings for scenario analysis

Asset efficiency level	HVAC	Lighting	Walls	Windows	Plug load and occupant density	Lighting, plug, occ schedules
High	90.1-2013	90.1-2013	90.1-2013	90.1-2013	90.1-2013	90.1-2013
Medium	90.1-2004	90.1-2004	90.1-2004	90.1-2004	90.1-2013	90.1-2013
Low	90.1-2004	90.1-2004	pre-1980	pre-1980	90.1-2013	90.1-2013

We used the DOE prototype models²¹ as the basis for our models. These models were developed to be representative of given building types and sizes and have been used extensively for stock-level energy analysis. We then modified selected parameters as indicated in Table 7. All other parameters remained the same as the prototype model. It should be noted that the large office building model includes a data center that accounts for about a third of the total energy use of the building. We did not vary the efficiency level of the data center.

Figure 7 shows the building geometry and typical floor thermal zones for the large office model. The key characteristics of the building geometry and HVAC type are listed in Table 8.

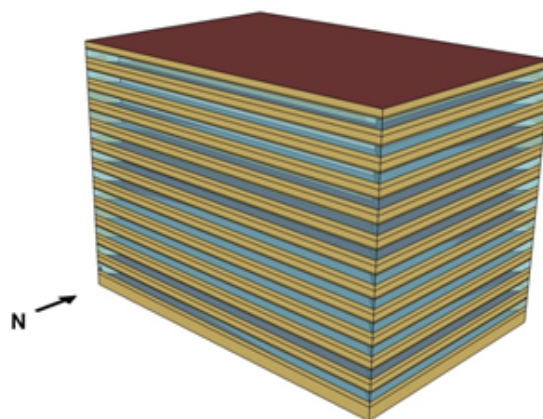

Figure 7. Large office building model geometry and thermal zones

²¹ https://www.energycodes.gov/development/commercial/prototype_models

Table 8. Building characteristics for large office building model.

Total Floor Area (ft ²)	498,600
Occupant density (ft ² /per)	200
Lighting load (W/ft ²)	0.82
Plug load (W/ft ²)	0.75
Building Shape	Rectangular
Aspect Ratio	1.5
Number of Floors	12 + Basement
Window Fraction (Window to Wall Ratio)	40% of above-grade gross walls
Thermal Zoning	Four perimeter zones, one core zone and one IT closet zone per floor. Perimeter zone depth: 15 ft. Datacenter zone is 28% of the basement floor area.
Floor to Ceiling Height (ft)	9
Floor to Floor Height (ft)	13
Roof type	Built-up roof, insulation entirely above deck
Exterior Wall Type	Steel-framed mass wall
Exterior Walls – Gross Area (ft ²)	124,750
Exterior Walls – Net Area (ft ²)	74,850
Roof Construction Type	Roof membrane + Roof insulation + metal decking
Roof - Total Area (ft ²)	38,350
Window Total Area (ft ²)	49,900
Infiltration (ACH)	0.746
Heating Type	Gas hot water boiler
Cooling Type	Water-source DX cooling coil with fluid cooler for the datacenter and IT closets. Two water-cooled centrifugal chillers for the rest of the building
Fan Control	Constant speed fan for data centers and variable speed fan for the rest of the building
Ventilation (L/s·per)	8
Service Water Heating Type	Storage tank
Service Water Fuel	Natural gas
Boiler Thermal Efficiency (%)	80
Hot Water Setpoint (°F)	140

The models for each building and climate were parametrically varied for a range of operational practices and weather years, as described below.

6.2 Variations in Operational Parameters

The quality of building operational practice varies widely and is difficult to characterize and categorize, especially given the heterogeneity of buildings. For this analysis, three levels of practice – good, average, and poor – for various operational parameters were defined based on a similar prior study (Mathew et al. 2012, Wang et al. 2012). The intent of this analysis is to illustrate the range of impacts due to different operational practices. It should be noted that the range of impacts for any given building will depend on the specific characteristics of that building.

Table 9 summarizes the range of practice modeled for various operational parameters. Good practice represents design intent or optimal performance of the building. For average and poor practice, the analysis assumes the building has the capability to run at the good practice level, but runs less efficiently due to poorer facility management. It should be noted that levels of practice vary widely across the building stock and what is considered average in one region or organization may be different in another region or organization. The intent of this scenario analysis is to characterize a reasonable range of practice. It should also be noted that the list of operations parameters modeled is not comprehensive and there are several other operational parameters that affect energy use but were not part of this analysis, due to modeling limitations or scope (e.g., maintenance, static pressure reset, building pressure control).

Table 9. Range of practice for various operations parameters

Factor	Good practice	Average practice	Poor practice
Lighting controls	Daylight-dimming + occ sensor	Occ sensor only	Timer only
Plug load controls	Turn off when occupants leave	Sleep mode by itself	No energy saving measures
HVAC schedule	optimal start	2hr +/- Occupant sch	n/a
Thermostat settings	68°F heating and 78°F cooling Setback: 60 - 85	70°F heating and 76°F cooling Setback: 68 - 80	72°F heating and 74°F cooling No setback
Supply air temp reset	SAT reset base on warmest zones	SAT reset based on stepwise function of outdoor air temperature	Constant supply air temperature
VAV box min flow settings	15% of design flow rate.	30% of design flow rate.	50% of design flow rate.
Economizer controls	Enthalpy	dry bulb	none/broken
Chilled water supply temp reset	Reset chilled water temperature based on cooling demand.	Linear relationship with outside air temp (OAT).	No reset with constant year-round.
Chiller sequencing	Kick on the lag chiller when the lead chiller reaches its peak efficiency.	Kick on the lag chiller when the chilled water temperature cannot be maintained.	Always running two chillers
Hot water supply temp reset	Reset the hot water supply temperature according to heating load.	Linear relationship with OAT.	No reset with constant year-round.

Figure 8 presents the annual source EUI variation due to the range of practice for each operational parameter for three levels of asset efficiency for climate zone 2A (warm-humid, represented by Houston, Texas). Figure 9 presents the same for climate zone 4A (mixed-humid, represented by Baltimore, Maryland). The figures show the impact of good and poor practice relative to average practice. For example, per Figure 8, medium asset efficiency in climate zone 4A shows that poor practice for VAV minimum flow control can cause a ~7% increase in source EUI relative to average practice and good practice causes a ~2% decrease in source EUI relative to average practice. Thus, the overall range is ~9%.

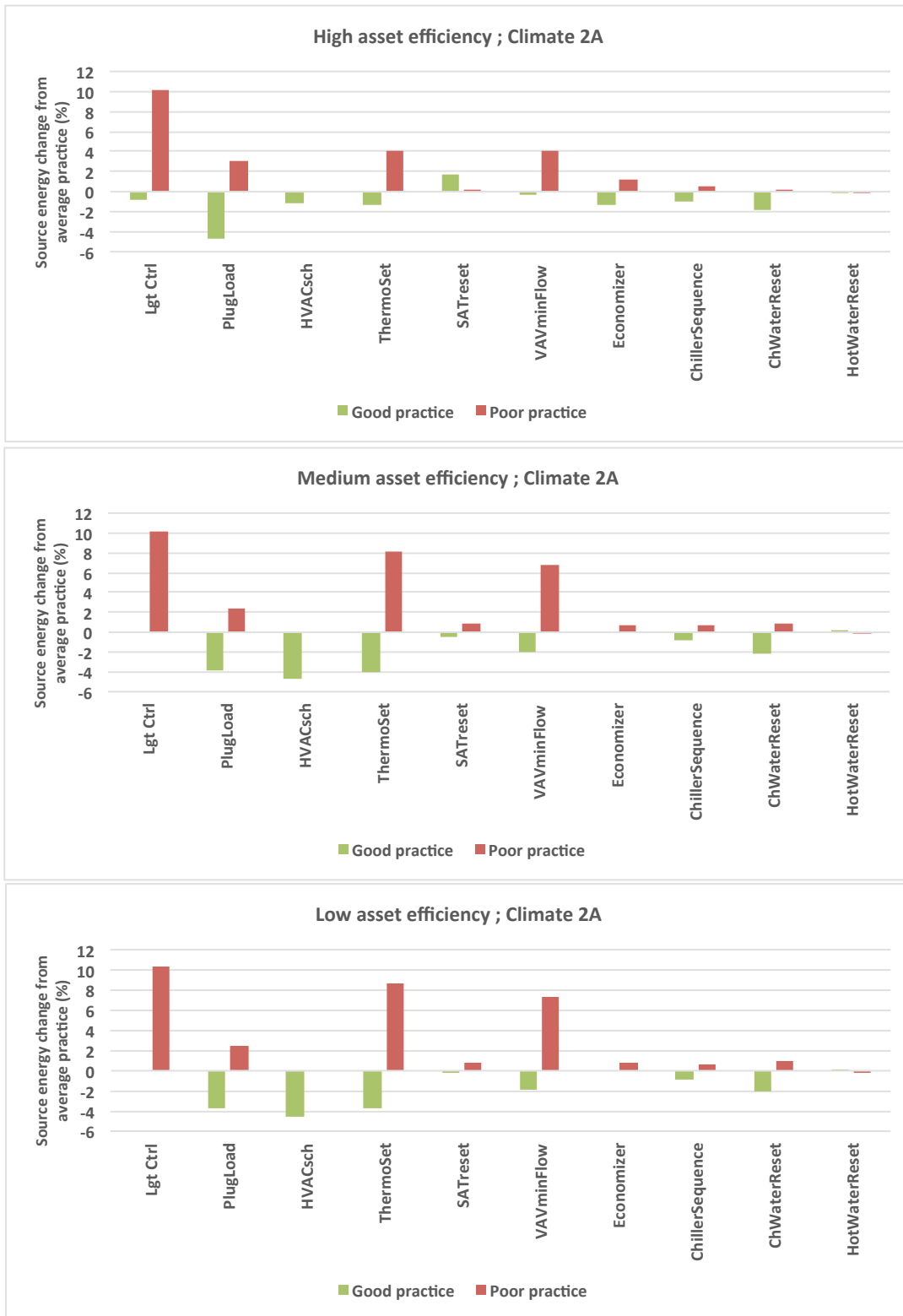

Figure 8. Relative impact of operations parameters in climate zone 2A (warm humid, similar to Houston, TX) for large office buildings with high (top), medium (middle), and low (bottom) asset efficiency.

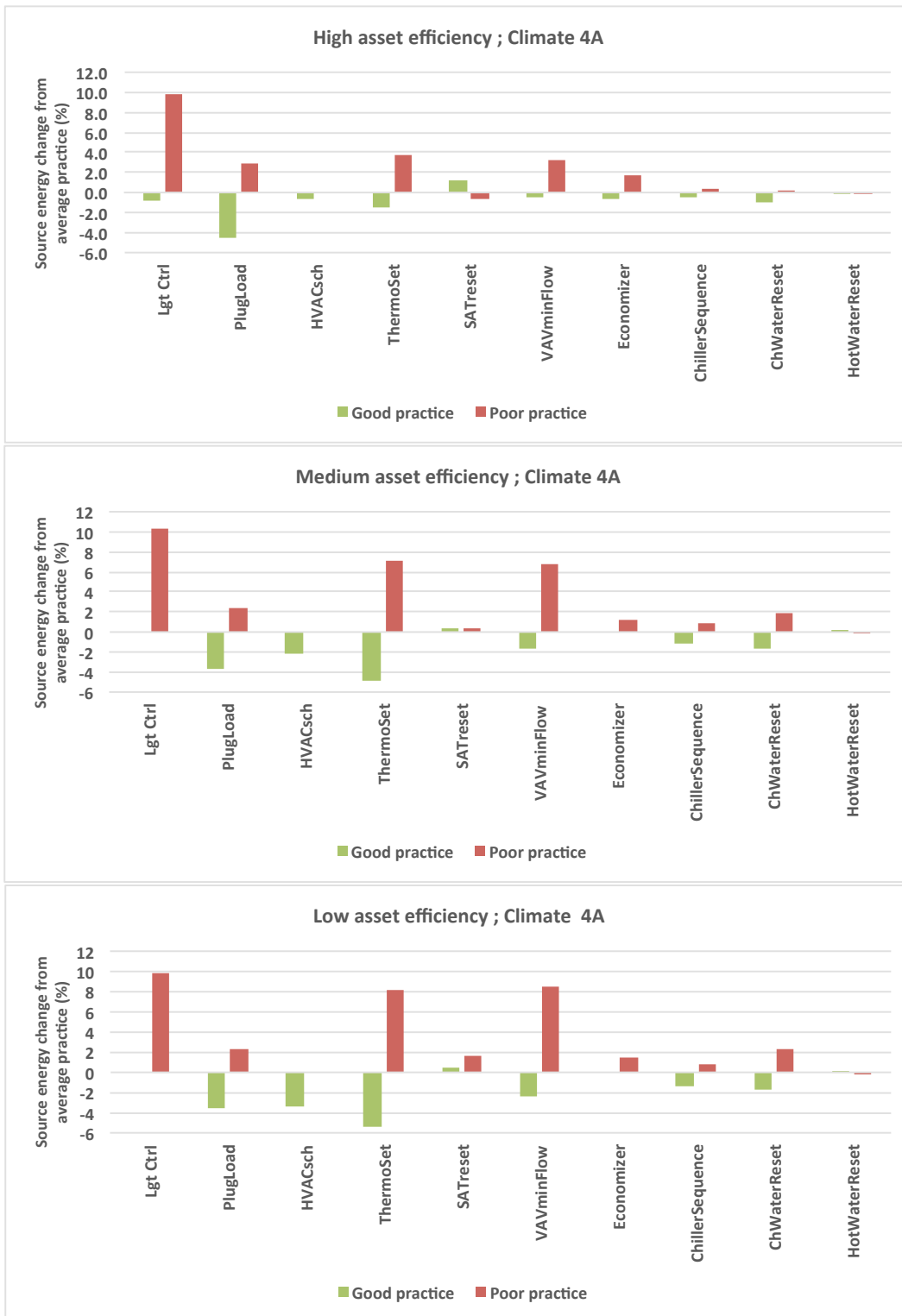

Figure 9. Relative impact of operations parameters in climate zone 4A (mixed humid, similar to Baltimore) for large office buildings with high (top), medium (middle), and low (bottom) asset efficiency.

Some observations worth noting are:

- Lighting control, thermostat settings and variable air volume (VAV) minimum flow control generally show the greatest impact.
- In general, the reduction in energy use from average to good practice is much less than the increase in energy use due to poor practice.
- The range of these results is largely consistent with evidence from commissioning projects.

Next, we analyzed the combined impact of poor and good practice (relative to average) in all parameters, with results shown in Figure 10. These results, in effect, demonstrate the outer bounds of the range of impact.

- The combined impacts of these operational parameters are significant in both climate zones, for all asset efficiency levels. Good practice reduces source EUI relative to average practice by 10-16% in climate zone 2A and 9-12% in climate zone 4A. Poor practice increases source EUI 25-33% in climate zone 2A and 33-45% in climate zone 4A. As a point of comparison, capital-intensive aggressive retrofits typically yield savings in the 20-40% range. Therefore poor operational practices could effectively negate the savings from aggressive retrofits.
- The range of impact is lower for buildings with higher asset efficiency. Stated differently, operational practices have a greater impact in buildings with poorer asset efficiency.
- Again, note that these variations are just the effect of operational practices, and not differences in fixed asset characteristics. That is, two identical buildings with the same building construction and equipment can show wide variation in energy use just due to their operational practices.

As a sensitivity test, we also modeled a medium-sized office building with medium asset efficiency in climate zone 4A, with results shown in Figure 11. The HVAC system for the medium office is packaged rooftop units (RTU) while the large office model has a central HVAC plant. Therefore, some of the HVAC operational parameters used for the large office analysis do not apply. The combined effect of poor practice across all parameters in the medium-sized office building resulted in source EUI increasing by 110% over average practice. Good practice yielded a reduction of 18%. Thus, the relative impacts are much higher for the medium office building (compare to Figure 10). Part of the reason for this is that the large office model includes a data center that was a significant portion of the total load and did not vary across the parametric analysis. Therefore this reduced the overall relative impacts. This underscores the earlier point that the range of impacts will vary based on the specific characteristics of any given building.

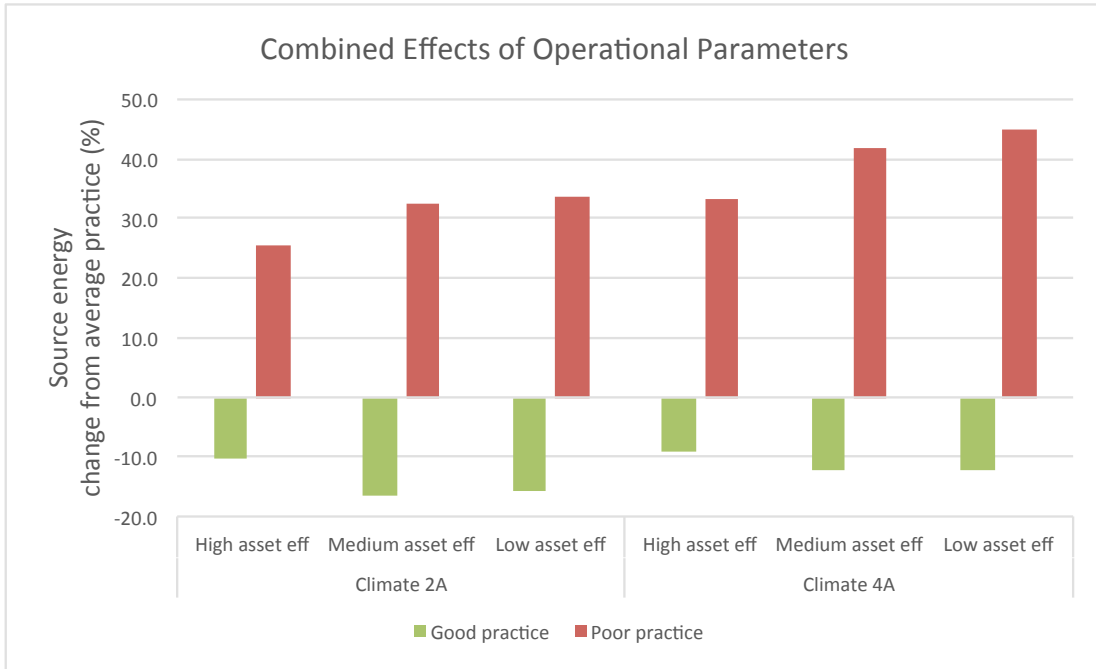

Figure 10. Combined impact of poor and good practice across all operational parameters for large office buildings in climate zones 2A (Houston) and 4A (Baltimore), for high, medium, and low asset efficiency.

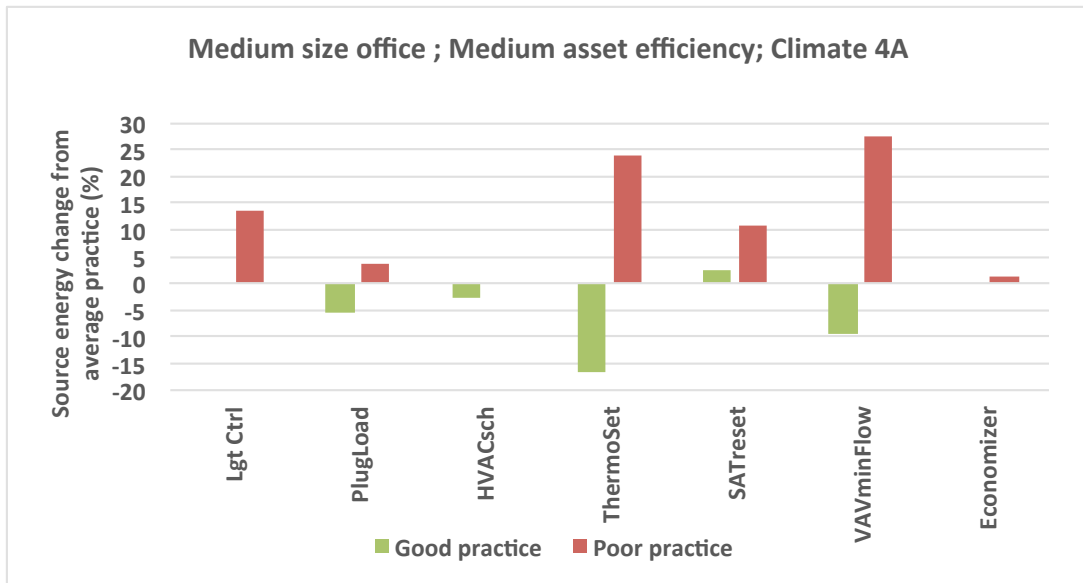

Figure 11. Relative impact of operations parameters for medium-sized office building with medium asset efficiency in climate zone 4A (mixed humid, similar to Baltimore).

6.3 Variations Due to Weather

Year-to-year variation in weather can change total source EUI, all others parameters being constant i.e., hotter summers will cause more cooling energy use and colder winters will cause more heating energy use, driving up annual source EUI for the building. In order to assess the relative impact of these year-to-year differences, we ran the models using actual weather data for 15 years (from 2001 to 2015) for both climate zones, and for all three asset efficiency levels. The actual weather data were obtained from a commercial weather data vendor. In all models we assumed average level of practice for operational parameters.

Figure 12 shows the % change in source EUI for each year relative to the average source EUI over 15 years. The overall range is only -1% to +1.5%. This suggests that year-to-year weather variations in a given location are not a significant source of volatility for annual source EUI for large office buildings. The impacts may be larger for perimeter-dominated smaller buildings. Note that these impacts are for *annual* source EUI. The *seasonal* impacts (e.g., for cooling energy in summer) may be much higher, but those can be compensated for over the course of a year (e.g., a year with an unusually hot summer may have a mild winter). Finally, we are careful to note that this finding should not be confused and conflated with climate variations; i.e., the variations between different locations. It refers only to year-on-year weather variations for a given location.

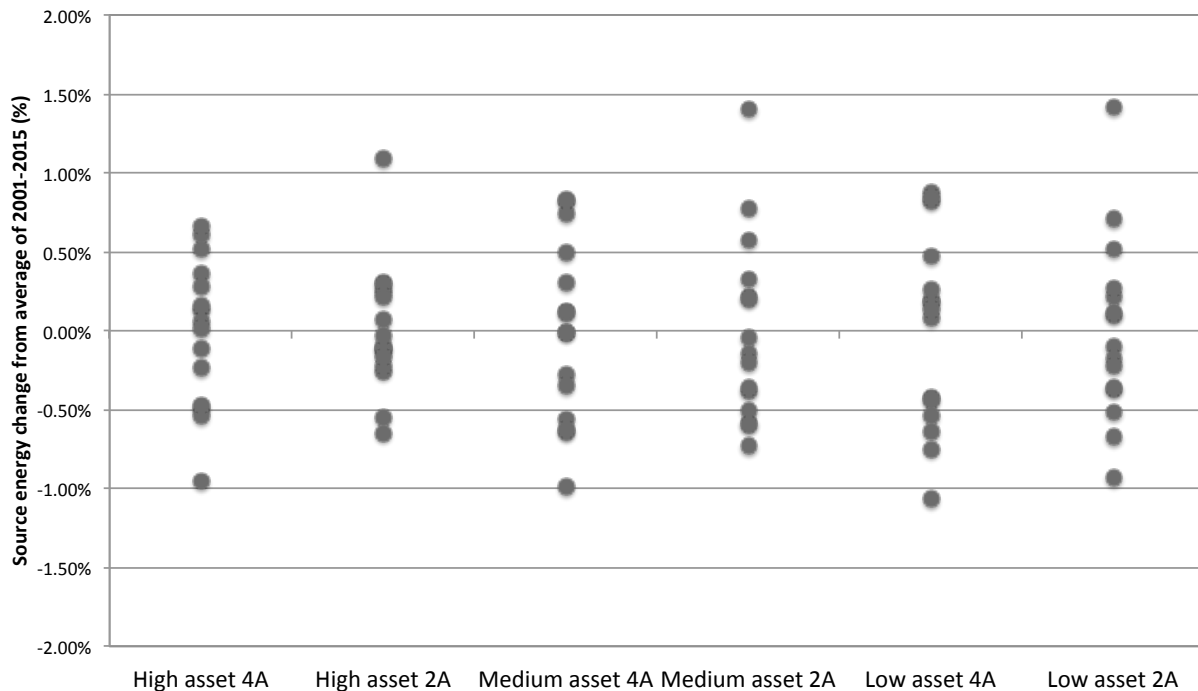

Figure 12. Year-to-year weather variations from 2001-2015 for large office buildings in climate zones 2A and 4A, for high, medium, and low asset efficiency and average operations practices.

6.4 Impact of Source EUI Variations on Default Risk

In order to characterize how these variations in source EUI translate into variations in default risk, we extended the scenario analysis as follows. We used the DOE Building Performance Database (BPD) to obtain a median source EUI for large office buildings in each of the climate zones. The BPD contains measured building performance data on over 220,000 non-residential buildings – the largest publicly available dataset of measured energy performance of building in the US. For example, Figure 13 shows a median source EUI of 172 kBtu/sf for large office buildings in climate zone 2A. We then applied the relative impacts of poor and good operational practices, high and low asset efficiency, and 2001-2015 weather variations from the simulation analysis to these empirical source EUI values to obtain the absolute values for the range of variation in source EUI. Finally, these absolute values were used with the coefficients from the default risk logistic regression model to obtain a change in default risk due to these variations in source EUI. Table 10 summarizes the results, which also show the default risk relative to the Trepp average default risk of 8%.

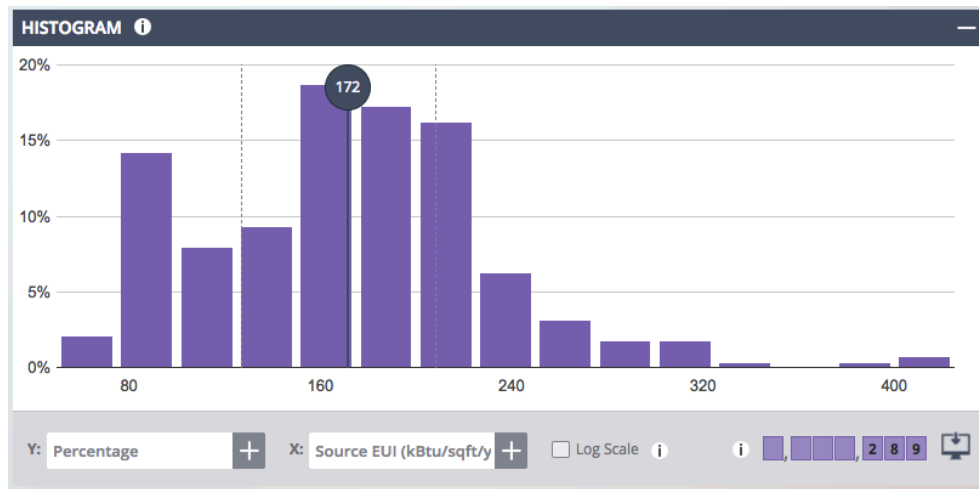

Figure 13. Source EUI distribution for office buildings in climate zone 2A with floor area between 300,000-700,000 sf.

Table 10. Impact of source EUI variations on default risk.

Case	Source EUI change from basecase (%)	Source EUI (kBtu/sf.yr)	Default risk change (basis points)	Default risk change from TREPP avg. (%)
2A Basecase	-	172	-	-
2A Poor practice	+32.5%	228	+90	+11.2%
2A Good practice	-16.5%	144	-57	-7.2%
2A Low asset efficiency	+0.8%	173	+3	+0.3%
2A High asset efficiency	-20.3%	137	-72	-9.0%
2A Weather 2001-15 high	+1.4%	174	+4	+0.6%
4A Basecase	-	169	-	-
4A Poor practice	+41.7%	239	+111	+13.4%
4A Good practice	-12.2%	148	-41	-5.2%
4A Low asset efficiency	+2.1%	173	+7	+0.8%
4A High asset efficiency	-15.6%	143	-54	-6.7%
4A Weather 2001-15 high	+0.8%	170	+3	+0.3%

The results show that poor operational practices increase default risk by 90 basis points (11.2% increase relative to Trepp average) for the building in climate zone 2A and 111 basis points (13.4% increase relative to Trepp average) for the building in climate zone 4A. Good operational practices decrease default risk by 57 basis points (7.2% decrease relative to TREPP average) for the building in climate zone 2A and 41 basis points (5.2% decrease relative to TREPP average) for the building in climate zone 4A.

High asset efficiency decreases default risk by 72 basis points (9% decrease relative to Trepp average) for the building in climate zone 2A and 54 basis points (6.7% decrease relative to Trepp average) for the building in climate zone 4A.²²

7 Conclusions

This is a first study of the effects of building-level energy consumption and the time-series risk of energy prices on the default risk of commercial mortgages. We apply measures of energy consumption using information on buildings' source and site EUIs obtained from a unique data set that merges the building-level data collected through the benchmarking ordinances of six cities with origination and performance data for commercial mortgages that have been securitized into commercial mortgage backed securities (CMBS). We develop a unique measure of locational energy price risk called the electricity price gap, computed as the difference between realized and expected electricity prices since the date of loan origination. We find that building-level energy consumption and the electricity price gap are statistically and economically associated with commercial mortgage defaults. Using building energy simulations, we find that building asset characteristics and operational practices that affect source EUI can have very important effects on the likelihood of default. Overall these results suggest that building level energy efficiency and locational price risk do move the needle on default and these factors should be included in the risk evaluations of new mortgage originations.

8 References

- An, X., Y. Deng, J. B. Nichols, and A. B. Sanders, 2013, The effects of sustainability features on mortgage default prediction and risk in multifamily rental housing, *Journal of Real Estate Finance and Economics* 47, 787–813.
- An, X., and G. Pivo, 2015, Default risk of securitized commercial mortgages: Do sustainability property feature matter?, Working paper, Arizona State University.
- BOMA Experience and Exchange Report for 2009, <http://www.boma.org/resources/benchmarking/Pages/default.aspx>.
- Deng, Y., and J. Wu, 2014, Economic returns to residential green building investment: The developers' perspective, *Regional Science and Urban Economics* 47, 35–44.

²² Low asset efficiency has negligible effect on default risk in this scenario because the only difference between the low and medium asset model is the wall and window efficiency which has relatively little impact in a large office building with a high data center load.

- Eichholtz, P., N. Kok, and J. Quigley, 2010, Doing well by doing good? Green office buildings, *American Economic Review* 100, 2492–2509.
- Eichholtz, P., N. Kok, and J. Quigley, 2013, The economics of green building, *Review of Economics and Statistics* 95, 50–63.
- Fuerst, F., and P. McAllister, 2011, The effects of sustainability features on mortgage default prediction and risk in multifamily rental housing, *Real Estate Economics* 39, 45–69.
- Ghent, A., and R. Valkanov, 2015, Comparing securitized and balance sheet loans: Size matters, Working paper, the University of Wisconsin.
- Jaffee, D., R. Stanton, and N. Wallace, 2013a, Energy efficiency and commercial-mortgage valuation, Working paper, U. C. Berkeley.
- Jaffee, D., R. Stanton, and N. Wallace, 2013b, Energy factors, leasing structure and the market price of office buildings in the U.S., Working paper, U. C. Berkeley.
- Kau, J., and D. C. Keenan, 1995, An overview of the option-theoretic pricing of mortgages, *Journal of Housing Research* 6, 217–244.
- Mathew, P., Pang, X., Wang, L. Determining Energy Use Volatility for Commercial Mortgage Valuation. June 2012. LBNL-5797E.
- Mathew, P., Coleman, P., Wallace, N., Issler, P., Kolstad, L., Sahadi, R. Energy Factors in Commercial Mortgages: Gaps and Opportunities. Technical Report. Lawrence Berkeley National Laboratory. May 2016. LBNL-1006378
- Mathew, P., N. Wallace, E. Alschuler, and L. Kolstad, August, 2016, Commercial mortgages: An under-utilized channel for scaling energy efficiency investments? Technical report, American Council for an Energy Efficient Economy, Proceedings of the ACEEE Summer Study on Energy Efficiency in Buildings.
- More, M. J., and L. D. Kirsch, February, 2013, Retail choice in electricity: What have we learned in 20 years?, Technical Report 2013-83, Christensen Associates Energy Consulting, Working paper prepared for Electric Markets Research Foundation.
- Rosen, S., 1974, Hedonic prices and implicit markets: Production differentiation in pure competition, *Journal of Political Economy* 82, 34–55.
- Schwartz, E. S., and W. N. Torous, 1989, Prepayment and the valuation of mortgage-backed securities, *Journal of Finance* 44, 375–392.
- Seslen, T., and W. Wheaton, 2010, Contemporaneous loan stress and termination risk in the cmbs pool: How “ruthless” is default?, *Real Estate Economics* 38, 211–246.
- Stanton, R., and N. Wallace, 2014, CMBS subordination, ratings inflation, and regulatory- capital arbitrage, Working paper, U. C. Berkeley.
- Titman, S., and W. N. Torous, 1989, Valuing commercial mortgages: An empirical investigation of the contingent-claims approach to pricing risky debt, *Journal of Finance* 43, 345–374.
- Vandell, K., and J. Lane, 1989, The economics of architecture and urban design: Some preliminary findings, *AREUEA Journal* 17, 121–136.
- Wang, L., Mathew, P., Pang, X. 2012. “Uncertainties in Energy Consumption Introduced by Building Operations and Weather for a Medium-Size Office Building.” *Energy and Buildings* 53 (2012) 152–158.